

Remeha

en

Fuel oil/gas boilers

P 420



Installation and Service Manual

Declaration of conformity

The appliance complies with the standard model described in declaration of compliance . It is manufactured and distributed pursuant to the requirements of european directives. The original declaration of conformity is available from the manufacturer.

**DÉCLARATION DE CONFORMITÉ CE
EG - VERKLARING VAN OVEREENSTEMMING
EC - DECLARATION OF CONFORMITY
EG - KONFORMITÄTSERKLÄRUNG**

Fabricant/Manufacturer/Hersteller/Fabrikant : REMEHA B.V
Adresse/Adress/Adress : Kanalzuid 110
Ville, pays Stad, Land/City, Country/Land, Ort : NL 7332 BD APELDOORN
Tel : +31 55 549 69 69
Fax : +31 55 549 64 96

déclare ici que les produit(s) suivant(s) : P 420
verklaart hiermede dat de toestel(len) 8, 9, 10, 11, 12, 13, 14 éléments

this is to declare that the following product(s)
erklärt hiermit das die Produk(te)

Mise en circulation par : voir fin de notice

répond/répondent aux directives CEE suivantes:
voldoet/voldoen aan de bepalingen van de onderstaande EEG-richtlijnen:
is/are in conformity with the following EEC-directives:
den Bestimmungen der nachfolgenden EG-Richtlinien entspricht/entsprechen:

CEE-Directive:	92/42/CEE	normes appliquées, toegepaste normen:
EEG-Richtlijn:	92/42/EEG	tested and examined to the following norms:
EEC-Directive:	92/42/EEC	verwendete Normen:
EG-Richtlinie:	92/42/EWG	EN 303.2(1999), EN 304(1993)
	73/23/CEE	DIN EN 50165(2001) EN 50165 (1997+A1:2001)
	73/23/EEG	DIN EN 60335-1(2003), EN 60335-1(2002)
	73/23/EEC	
	73/23/EWG	
	89/336/CEE	EN 55014-1(2000+A1:2001)
	89/336/EEG	EN 55014-2(1997+A1:2001)
	89/336/EEC	EN 61000-3-2(2000),
	89/336/EWG	EN 61000-3-3(1995+A1:2001) EN55022 classe B (1998+A1 :2000)
	97/23/CEE	(art.3 section 3)
	97/23/EEG	(art. 3, lid 3)
	97/23/EEC	(article 3, sub 3)
	97/23/EWG	(Art. 3, Absatz 3)



Mertzwiller, 27 mai 2008

Jean-Claude GIRARDIN
Directeur des opérations industrielles
Recherche et développement

C001880

Contents

1	Safety instructions	4
1.1	General safety instructions	4
1.2	Recommendations	5
1.3	Liabilities	5
2	About this manual	6
2.1	Symbols used in the manual	6
2.2	Abbreviations	6
2.3	Homologations	6
3	Technical description	7
3.1	General description	7
3.2	Technical specifications	7
4	Installation	8
4.1	Regulations governing installation	8
4.2	Package list	8
4.3	Choice of the location	8
4.4	Example of an installation	11
4.5	Hydraulic connections	12
4.6	Chimney connection	14
4.7	Fuel-oil or gas connections	15
4.8	Electrical connections	15
4.9	Filling the system	15
5	Commissioning	16
6	Switching off the boiler	16
6.1	Precautions required in the case of long boiler stops	16
6.2	Precautions required if the heating is stopped when there is a risk of freezing	16
7	Checking and maintenance	17
7.1	System maintenance	17
7.2	Type plate	17
7.3	Maintenance	18
7.4	Cleaning the casing material	21
7.5	Maintenance of the burner	21
8	Spare parts	22

1 Safety instructions

Danger

This appliance can be used by children aged from 8 years and above and persons with reduced physical, sensory or mental capabilities or lack of experience and knowledge if they have been given supervision or instruction concerning use of the appliance in a safe way and understand the hazards involved. Children shall not play with the appliance. Cleaning and user maintenance shall not be made by children without supervision.

 Any operation on the installation must be performed by a qualified technician respecting professional regulations and in accordance with this document.

 Before any work, switch off the mains supply to the appliance. Protect the installation against any unwanted restarts.

 For a proper operating of the boiler, follow carefully the instructions.

 The manufacturer is not liable for any improper use of the appliance or failure to maintain or install the unit correctly (the user shall take care to ensure that the system is installed by a qualified engineer).

 Work on electrical equipment must be carried out by a qualified professional in compliance with the prevailing regulations.

 Check that the appliance is properly set for the type of gas used.

 Keep to the polarity shown on the terminals: phase (L), neutral (N) and earth \perp .

 Check the seal on the gas and water pipe connections.

 We shall not accept any responsibility for any damage and disturbance arising from not following these instructions.

 Incorrect use or unauthorised modifications to the installation or the equipment itself invalidate any right to claim.

1.1 General safety instructions

1.1.1 Fire hazard

 Do not stock products of an inflammable nature close to the appliance.

 It is forbidden to store inflammable products and materials in the boiler room or close to the boiler, even temporarily.

 If you smell gas, do not use a naked flame, do not smoke, do not operate electrical contacts or switches (doorbell, lights, motor, lift, etc.):

1. Shut off the gas supply.
2. Open the windows.
3. Extinguish all flames.
4. Evacuate the premises.
5. Contact a qualified professional.
6. Inform the gas supplier.

1.1.2 Risk of intoxication

 Do not obstruct the air inlets in the room (even partially).

 If you smell flue gases

1. Switch the appliance off
2. Open the windows
3. Evacuate the premises
4. Contact a qualified professional

1.1.3 Risk of being burnt

 Depending on the settings of the appliance:

- The temperature of the flue gas conduits may exceed 60°C

- The temperature of the radiators may reach 95°C
- The temperature of the domestic hot water may reach 65°C

1.1.4 Risk of damage

 Do not stock chloride or fluoride compounds close to the appliance.

 Install the appliance in frost-free premises.

Do not neglect to service the appliance: Contact a qualified professional or take out a maintenance contract for the annual servicing of the appliance.

1.2 Recommendations

 For a proper operating of the boiler, follow carefully the instructions.

 Any intervention on the appliance and heating equipment must be carried out by a qualified engineer.

 The manufacturer is not liable for any improper use of the appliance or failure to maintain or install the unit correctly (the user shall take care to ensure that the system is installed by a qualified engineer).

 Work on electrical equipment must be carried out by a qualified professional in compliance with the prevailing regulations.

 Check that the appliance is properly set for the type of gas used.

 Keep to the polarity shown on the terminals: phase (L), neutral (N) and earth \perp .

 Check the seal on the gas and water pipe connections.

 We shall not accept any responsibility for any damage and disturbance arising from not following these instructions.

1.3 Liabilities

1.3.1 Manufacturer's liability

Our products are manufactured in compliance with the requirements of the various applicable European Directives. They are therefore delivered with **CE** marking and all relevant documentation. In the interest of customers, we are continuously endeavouring to make improvements in product quality. All the specifications stated in this document are therefore subject to change without notice.

Our liability as the manufacturer may not be invoked in the following cases:

- Failure to abide by the instructions on installing the appliance
- Failure to abide by the instructions on using the appliance
- Faulty or insufficient maintenance of the appliance

1.3.2 Installer's liability

The installer is responsible for the installation and commissioning of the appliance. The installer is required to observe the following instructions:

- Read and follow the instructions given in the manuals provided with the appliance
- Install the appliance in accordance with the legislation and standards currently in force
- Perform the initial start up and carry out any checks necessary
- Explain the installation to the user
- If a maintenance is necessary, warn the user of the obligation to check the appliance and maintain it in good working order
- Give all the instruction manuals to the user

2 About this manual

2.1 Symbols used in the manual



Caution danger

Risk of injury and damage to equipment. Attention must be paid to the warnings on safety of persons and equipment.



Reference

Refer to another manual or other pages in this instruction manual.



Specific information

Information must be kept in mind to maintain comfort.

2.2 Abbreviations

- ▶ **DHW:** Domestic hot water.
- ▶ **PPS:** Polypropylene hardly inflammable.
- ▶ **3CE:** Collective conduit for sealed boiler
- Hi:** Lower heating value LHV (Nett)
- Hs:** Higher heating value HHV (Gross)

2.3 Homologations

This product will be marketed in the following European Union member states:

NL - BE - ES - GB - HU - SE

with a gas or oil-burner of the associated category.

2.3.1 Directive 97/23/EC

Gas and oil boilers with a maximum operating temperature of 110°C and hot water tanks with a maximum operating pressure of 10 bar pertain to article 3.3 of the directive, and therefore, cannot be CE-marked to certify compliance with the directive 97/23 EC.

The boilers and hot water tanks are designed and manufactured in accordance with the sound engineering practice, as requested in article 3.3 of the directive 97/23/EC, it is certified by compliance with the directives 90/396/EC, 92/42/EC, 2006/95/EC and 2004/108/EC.

3 Technical description

3.1 General description

The boilers of the P 420 range are pressurised hot water boilers designed for connecting to a flue pipe which require a separate automatic fuel-oil or gas burner.

The useful power of P 420 boilers is between 250 and 700 kW.

Boiler with control panel, which may be fitted with an optional Rematic 2945 C3 control unit for heating only or heating and domestic hot water production.

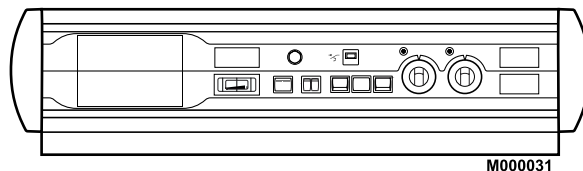

M000031

3.2 Technical specifications

Maximum operating pressure: 6 bar

Boiler thermostat setting: 30 to 90°C

Maximum operating temperature: 100°C

Boiler			P 420-8	P 420-9	P 420-10	P 420-11	P 420-12	P 420-13	P 420-14
Useful output		kW	300-390	390-450	450-540	540-600	600-670	670-720	720-780
Power input		kW	329-434	429-502	495-599	594-670	661-751	737-804	789-871
Number of sections			8	9	10	11	12	13	14
Water content		l	366	409	452	495	538	581	624
Water resistance	Δ T = 10K	mbar	31	48	80	101	130	158	194
	Δ T = 15K		14	21	36	45	58	70	87
	Δ T = 20K		8	12	20	25	33	40	49
Pressure in the furnace for nozzle pressure = 0 (1) (3) (2)		mbar	1.1	1.5	2.0	2.5	2.5	2.5	3.5
Smoke temperature (1) (3) (2)*		°C	< 220	< 220	< 220	< 220	< 220	< 220	< 220
Mass flue gas flow rate (1) (2)	Fuel oil	Kg/h	650	750	900	1000	1116	1200	1450
	Gas		700	810	972	1080	1207	1297	1405
Combustion chamber	Diameter, combustion chamber	mm	530	530	530	530	530	530	530
	Width, combustion chamber	mm	638	638	638	638	638	638	638
	Depth, combustion chamber	mm	1183	1343	1503	1663	1823	1983	2143
	Volume	m ³	0.310	0.354	0.396	0.439	0.481	0.523	0.565
Maintenance consumption*	à 50°C	W	315	358	413	451	494	505	555
Shipping weight		kg	1470	1650	1830	2010	2190	2370	2550

*Maintenance consumption: total heat emission when the burner is off as a percentage of the nominal input power when the difference between the mean boiler temperature and the room temperature is 30 K.

(1) Nominal operation (top boiler power)

(2) CO₂ = 13.1 to 13.5% with fuel oil and 9.5% with natural gas.

(3) Boiler temperature: 80 °C - Ambient temperature: 20 °C

4 Installation

4.1 Regulations governing installation

 Installation must be carried out in accordance with the prevailing regulations, the codes of practice and the recommendations in these instructions.

4.2 Package list

 See assembly instructions.

4.3 Choice of the location

4.3.1 Main dimensions

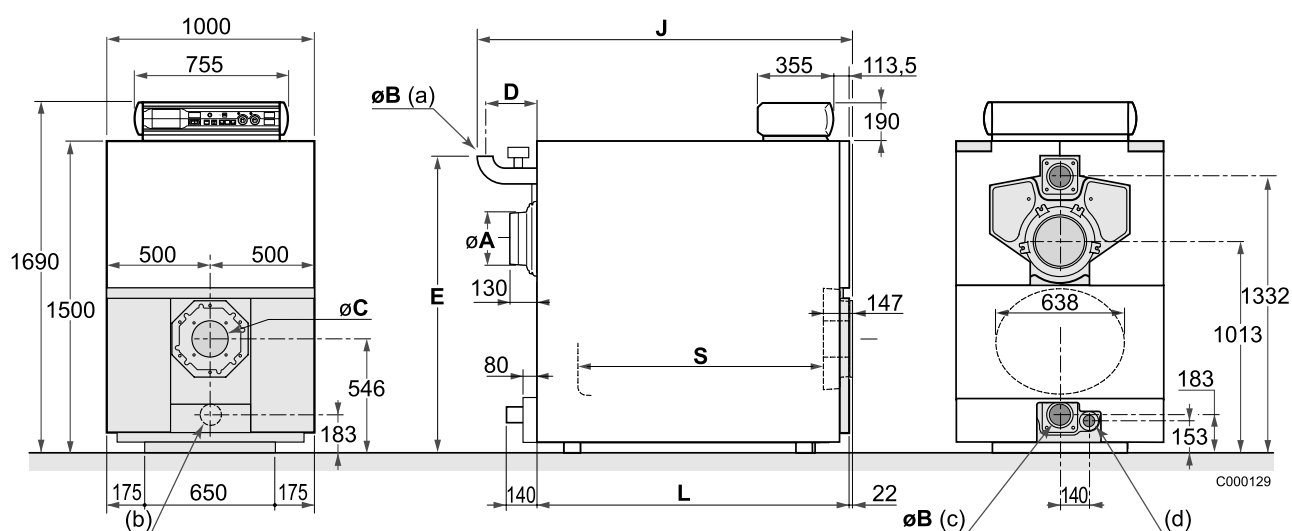

(a) Boiler flow - weld

(c) Boiler return - weld

(b) Sludge removal hole \varnothing Rp 2 1/2 - plugged

(d) Rp 2 draining outlet - plugged

Boiler type	P 420-8	P 420-9	P 420-10	P 420-11	P 420-12	P 420-13	P 420-14
\varnothing A	250	250	250	300	300	300	300
\varnothing B	2" 1/2	2" 1/2	2" 1/2	3"	3"	3"	3"
\varnothing C	plate intact or pre-drilled to the diameter specified on order						
D	235	235	235	254	254	254	254
E	1427	1427	1427	1447	1447	1447	1447
J	1800	1950	2120	2305	2465	2625	2785
L	1505	1665	1825	1985	2145	2305	2465
S	1183	1343	1503	1663	1823	1983	2143

4.3.2 Position of the boiler

For the assembly and because of their design, P 420 boilers require no special base. Their closed furnace system means that the floor need not have refractory properties. All you have to ensure is that the floor can support the weight of the boiler when it is fitted for operation.

If the boiler location is not determined precisely, leave enough space around the boiler to facilitate monitoring and maintenance operations.

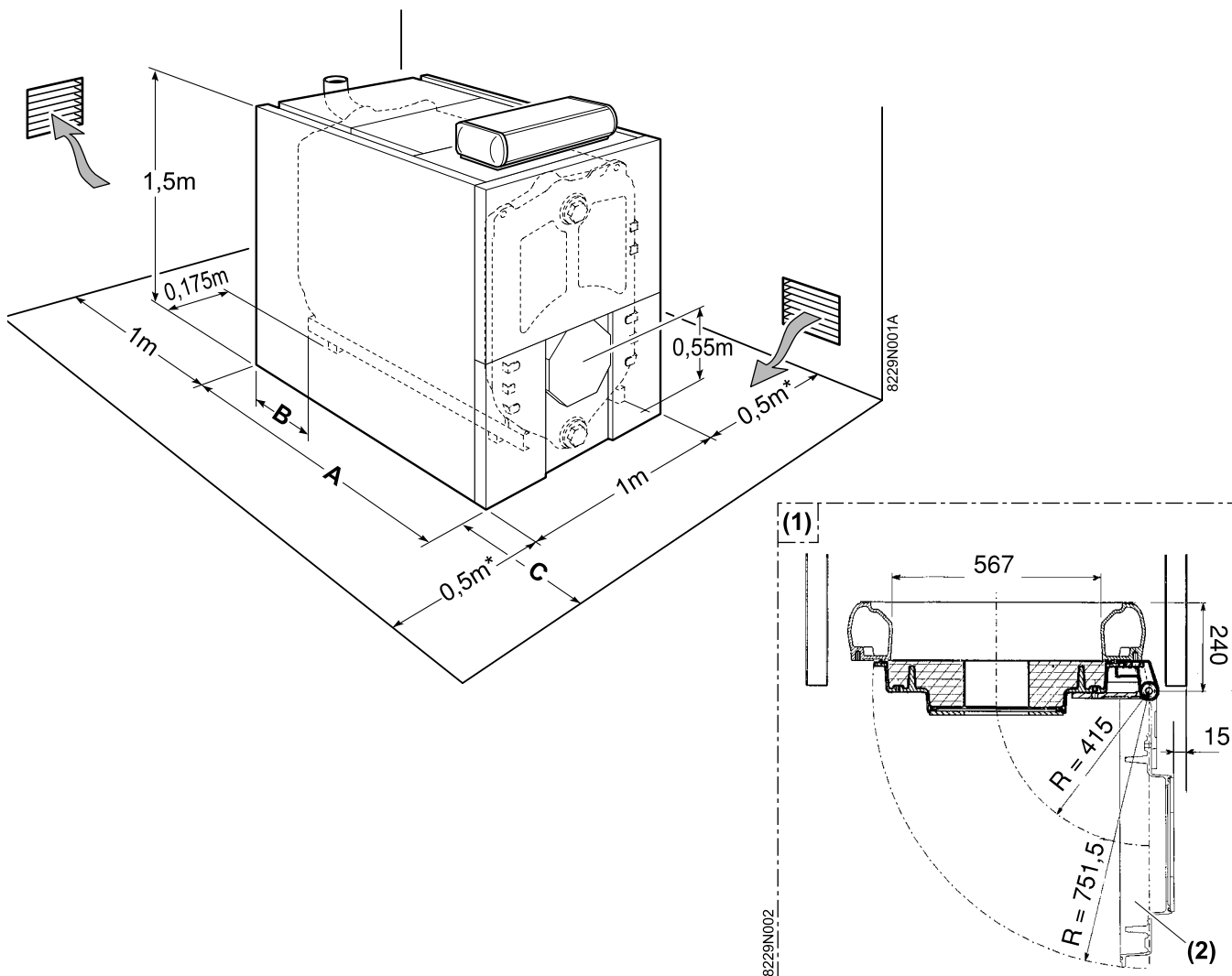

(1) Top view

(2) Burner door

	P 420-8	P 420-9	P 420-10	P 420-11	P 420-12	P 420-13	P 420-14
A	1505	1665	1825	1985	2145	2305	2465
B	130	-40	120	-40	120	-40	120
C	1.5	2	2	2	2.5	2.5	2.5

⚠ Caution: adapt the dimensions on the basis of the dimensions of the burner when the door is open.

4.3.3 Ventilation

The location of air inlets in relation to the high ventilation openings shall ensure that the air is renewed in the entire volume of the boiler room.

It is in any case imperative to conform to the local regulations in force.

 **Caution:**

In order to avoid damage to the boiler, it is necessary to prevent the contamination of combustion air by chlorine and/or fluoride compounds, which are particularly corrosive.

These compounds are present, for example, in aerosol sprays, paints, solvents, cleaning products, washing products, detergents, glues, snow clearing salts, etc.

Therefore:

- Do not pull in air evacuated from premises using such products: hairdressing salons, dry cleaners, industrial premises (solvents), premises containing refrigeration systems (risk of refrigerant leakage), etc.
- Do not stock such products close to the boilers.

If the boiler and/or peripheral equipment are corroded by such chloride or fluoride compounds, the contractual guarantee cannot be applied.

4.4 Example of an installation

Installation must be carried out in accordance with the prevailing regulations, the codes of practice and the recommendations in these instructions.

The expansion vessel must be connected directly to the boiler without valves or stop valves.

Likewise, the safety valve must be connected directly to the boiler without valves or stop valves.

Example of an installation:

The example of an installation shown below does not cover every possible configuration.

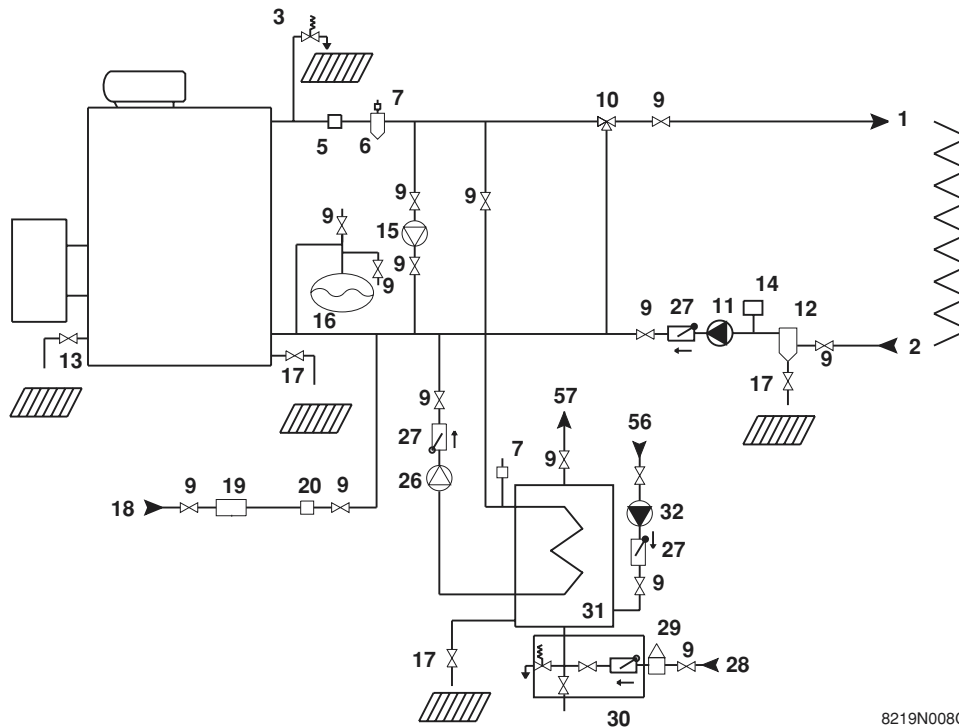

8219N008C

- | | | | |
|----|--|----|---|
| 1 | Heating flow | 17 | Drain cock |
| 2 | Heating return | 18 | Heating circuit filling (with disconnecter depending on prevailing regulations) |
| 3 | 3-bar safety valve + Pressure gauge | 19 | Water treatment |
| 5 | Flow switch | 20 | Water meter |
| 6 | Air separator | 26 | DHW load pump |
| 7 | Automatic air vent | 27 | Non-return valve |
| 9 | Isolating valve | 28 | Domestic cold water inlet |
| 10 | 3-way mixing valve | 29 | Pressure reducer (if mains pressure > 5.5 bar) |
| 11 | Boiler pump | 30 | Safety unit calibrated to 7 bar with indicator type discharge |
| 12 | Sludge decanting pot (particularly recommended on older installations) | 31 | Independent domestic hot water tanks |
| 13 | Flush valve | 32 | Domestic hot water loop pump (optional) |
| 14 | Water low safety pressure-sensitive switch | 56 | Domestic hot water circulation loop return |
| 15 | Shunt pump | 57 | Domestic hot water outlet |
| 16 | Expansion vessel | | |

4.5 Hydraulic connections

4.5.1 Flushing the system

■ Installing the boiler in new installations (installations less than 6 months old)

- ▶ Clean the installation with a universal cleaner to eliminate debris from the system (copper, hemp, flux).
- ▶ Thoroughly flush the installation until the water runs clear and shows no impurities.

■ Installing the boiler in existing installations

- ▶ Remove sludge from the installation.
 See: Sludge removal.
- ▶ Flush the installation.
- ▶ Clean the installation with a universal cleaner to eliminate debris from the system (copper, hemp, flux).
- ▶ Thoroughly flush the installation until the water runs clear and shows no impurities.

4.5.2 Sludge removal

A tapped Rp 2" 1/2 hole with a plug has been provided on the bottom of the front of the boiler. Fit a 1/4 turn valve (not supplied) on the opening to remove the sludge.

Sludge removal leads to the draining of large quantities of water, so remember to refill the system after the operation.

After this operation, go ahead and fill the installation.

 See: Filling the system.

i never replace a boiler in an existing system without carefully rinsing the system first. Install a sludge decanting pot on the return pipe, very close to the boiler.

4.5.3 Hydraulic connection of the heating circuit

■ Water flow in the boiler

The water flow in the boiler when the burner is operating must correspond with the following formulae:

- Nominal water flow $Q_n = 0.86 P_n / 20$.
- Minimum flow $Q_{min} = 0.86 P_n / 45$ (this flow also corresponds with the minimum recycle flow in the boiler).
- Maximum water flow $Q_{max} = 0.86 P_n / 5$.

Q_n = flow in m^3/h .

P_n = Nominal output (full boiler output) in kW.

- Operation at modulated low temperature (minimum outlet temperature: 40°C); The burner can modulate down to 50% of the nominal stage.

■ Operation in cascade

After stopping the burner:

- Timeout required before the order to close a 2 way valve: 3 min.
- Switch a possible shunt pump (located between the boiler and a butterfly valve) off via the end of run contact of the butterfly valve.

■ Operation with 2-stage burner

- The water temperature in the boiler is maintained at 50°C or more; The first stage must be set to a minimum of 30% of the nominal stage.
- Operation at modulated low temperature (minimum outlet temperature: 40°C); The first stage must be set to a minimum of 50% of the nominal stage.

■ Operation with modulating burner

- The water temperature in the boiler is maintained at 50°C or more: The burner can modulate down to 30% of the nominal stage.

4.5.4 Safety valve

The safety valve must be connected to the boiler outlet and no other valve or flap must be interposed between it and the boiler.

► **Minimum safety valve flowrate as a function of maximum boiler nominal output:**

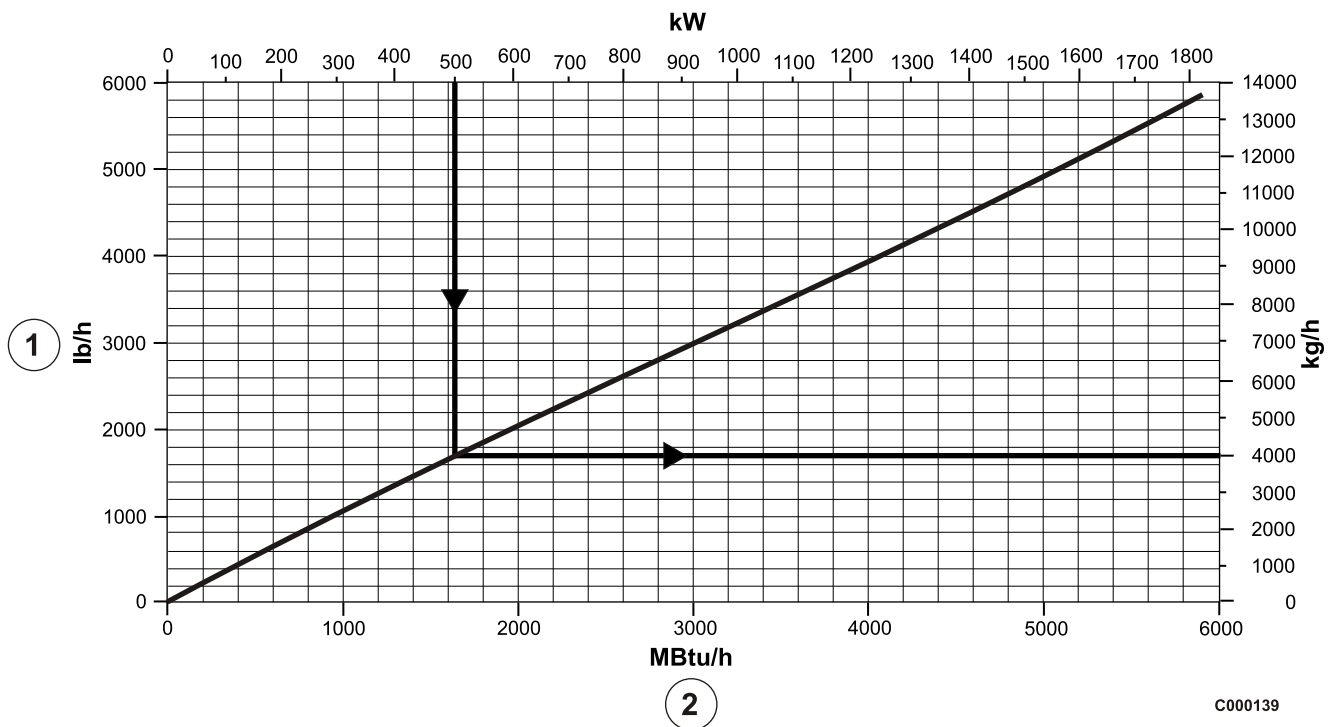

- ① Minimum relieving capacity
- ② Maximum gross boiler output

Example

Maximum boiler nominal output is 500 kW.

Minimum safety valve flowrate must be 4000 Kg/h

4.5.5 Connection of the water circuit for domestic use

 See: Domestic hot water calorifier instructions.

4.6 Chimney connection

The high-performance features of modern boilers and their use in specific conditions as a result of the advance in burner technology (e.g. first-stage or low modulation range operation) lead to very low flue gas temperatures (<160°C).

For this reason:

- Use flue gas pipes designed to enable the flow of condensates which may result from such operating modes in order to prevent damage to the chimney.
- Install a draining tee at the bottom of the chimney.

The use of a draught moderator is recommended as well.

4.6.1 Flue size

Refer to applicable regulations while determining the size of the flue. Please note that P 420 boilers have pressurised and tight furnaces and that the pressure at the connection to the chimney must not exceed 0 mbar, unless special sealing precautions have been taken, for instance in order to connect a static condenser/regenerator.

4.6.2 Connection to the flue gas pipe

The connection shall be removable, and offer minimum load losses, i.e. it must be as short as possible with no sudden change in section.

Its diameter shall always be at least equal to that of the boiler outlet, i.e.:

ø 250 mm: for 7 to 10 sections

ø 300 mm: for 11 to 14 sections.

4.7 Fuel-oil or gas connections

 Refer to the instructions supplied with the burner.

 **The burner head deflector must be flush with the insulation of the burner door.**

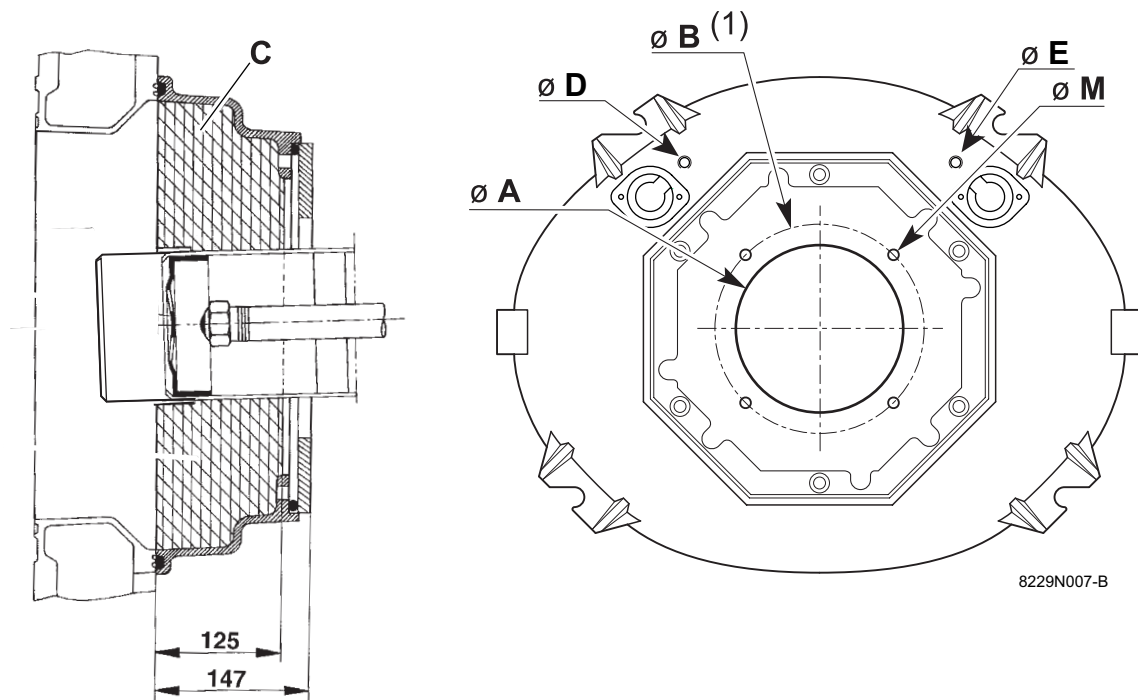

C: Furnace door insulation

D, E: Pressure gauge measurement socket

(1) Max attachment diameter:

- Max $\varnothing B = 290$ mm
- Max $\varnothing B = 330$ mm with 4 fastenings at 15° or 45°

$\varnothing A$	135	175	190	240	250	290
$\varnothing B$	170	200	220	270	325	330
$\varnothing D$	10	10	10	10	10	10
$\varnothing E$	10	10	10	10	10	10
$\varnothing M$	8	8	10	10	14	12

4.8 Electrical connections

 Refer to the connection instructions supplied with the control panel..

4.9 Filling the system

Filling shall be performed with a low flow rate from a low point in the boiler room in order to ensure that all the air in the boiler is bled from the high point of the system.

All the pumps must be stopped before filling (included shunt pump(s)).

 **Do not add cold water suddenly into the boiler when it is hot.**

 **VERY IMPORTANT: Instructions for starting up the boiler for the first time after the system is fully or partly drained: If all the air is not bled naturally to an expansion vessel which opens out onto the air, the system must include manual bleeder valves, in addition to automatic bleeder valves with the capability to bleed the system by themselves when it is operating, the manual bleeder valves are used to bleed all the high points of the system and to make sure that the filled system is free of air before the burner is turned on.**

5 Commissioning



See:

- Control panel instructions.
- Burner instructions.
- Domestic hot water calorifier instructions.

6 Switching off the boiler

- ▶ Set the On/Off switch to **O**.
- ▶ Cut the gas supply to the boiler (if present).

 See: Control panel instructions.

6.1 Precautions required in the case of long boiler stops

- The boiler and the chimney must be swept carefully.
- Close all the doors of the boiler to prevent air from circulating inside the boiler.
- We advise removing the pipe which connects the boiler to the chimney and to close off the nozzle with a cover.

6.2 Precautions required if the heating is stopped when there is a risk of freezing

We recommend the use of a correctly dosed antifreeze agent to prevent to the heating circuit from freezing.

If this cannot be done, drain the system completely.

7 Checking and maintenance

7.1 System maintenance

7.1.1 Water level

Regularly check the level of water in the system and top up if required, taking care that cold water is not added suddenly into the boiler when it is hot.

The use of an automatic filling is strongly discouraged.

This operation should be required only a few times in each heating season, with very low quantities of water; otherwise, look for the leak and repair it.

7.1.2 Draining

⚠ We advise you against draining the system unless it is absolutely necessary.

For example: Several months' absence with the risk of ice in the building.

7.2 Type plate

The rating plate fixed on the side of the boiler during installation is used to identify the boiler correctly and also provides the main specifications of the boiler.

- ① Boiler type
- ② Nominal output
- ③ Nominal input

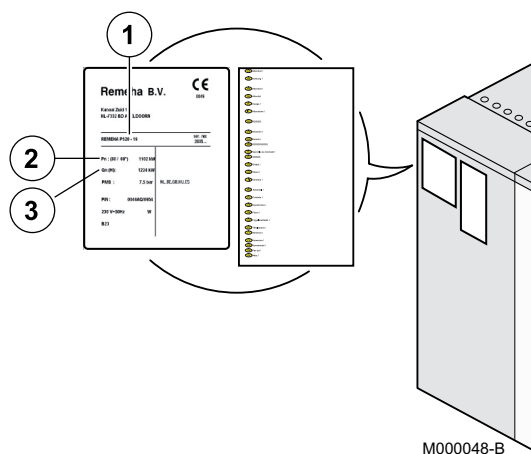

7.3 Maintenance

! The boiler will only operate efficiently if the exchange surfaces are kept clean.

The boiler should be cleaned as soon as required and as the chimney, **at least once a year or more**, depending upon applicable regulations and specific needs.

! The operations described below shall only be performed with the boiler and power supply off.

7.3.1 Cleaning the flue gas circuit

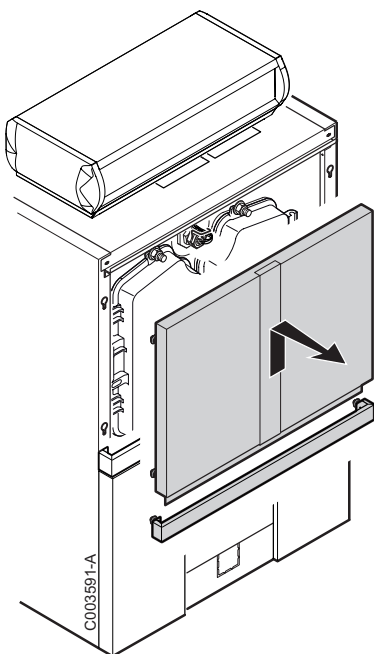

- Remove the upper front panel.
- Take off the lower panels.
- Open the sweeping doors (upper doors) by unscrewing the 3 nuts using a 19 mm spanner.
- Remove the baffle plates from the upper flue ways.

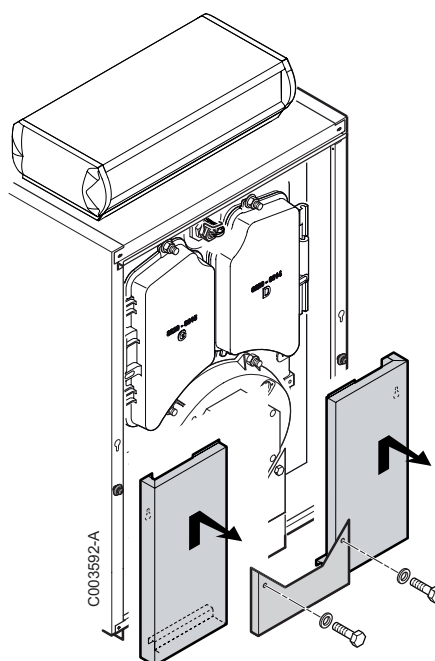

- Carefully sweep the flue ways with the brush supplied for that purpose.
- Brush the baffle plates.
- If possible, use a vacuum cleaner.
- Replace the baffle plates.
- Close the doors.

7.3.2 Cleaning the combustion chamber

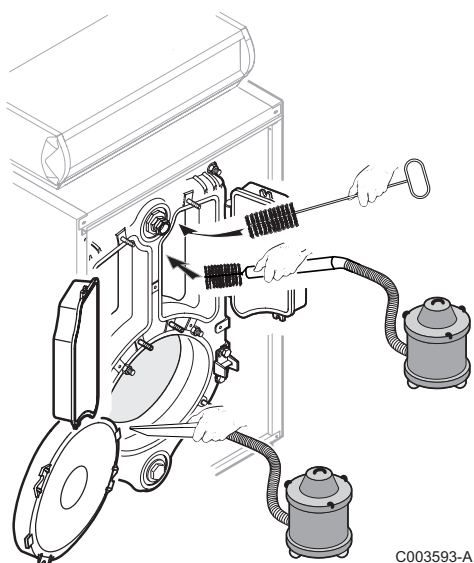

- Unscrew the 4 closing nuts and open the furnace door.
- Brush out the inside of the furnace.
- Use a vacuum cleaner to remove any soot which has accumulated in the combustion chamber.
- Close the door and replace the front panel.

7.3.3 Positioning of the baffle plates

- Put the baffle plates back in place and hook them into each other before engaging them fully in the flue way.
- Close the sweeping doors.

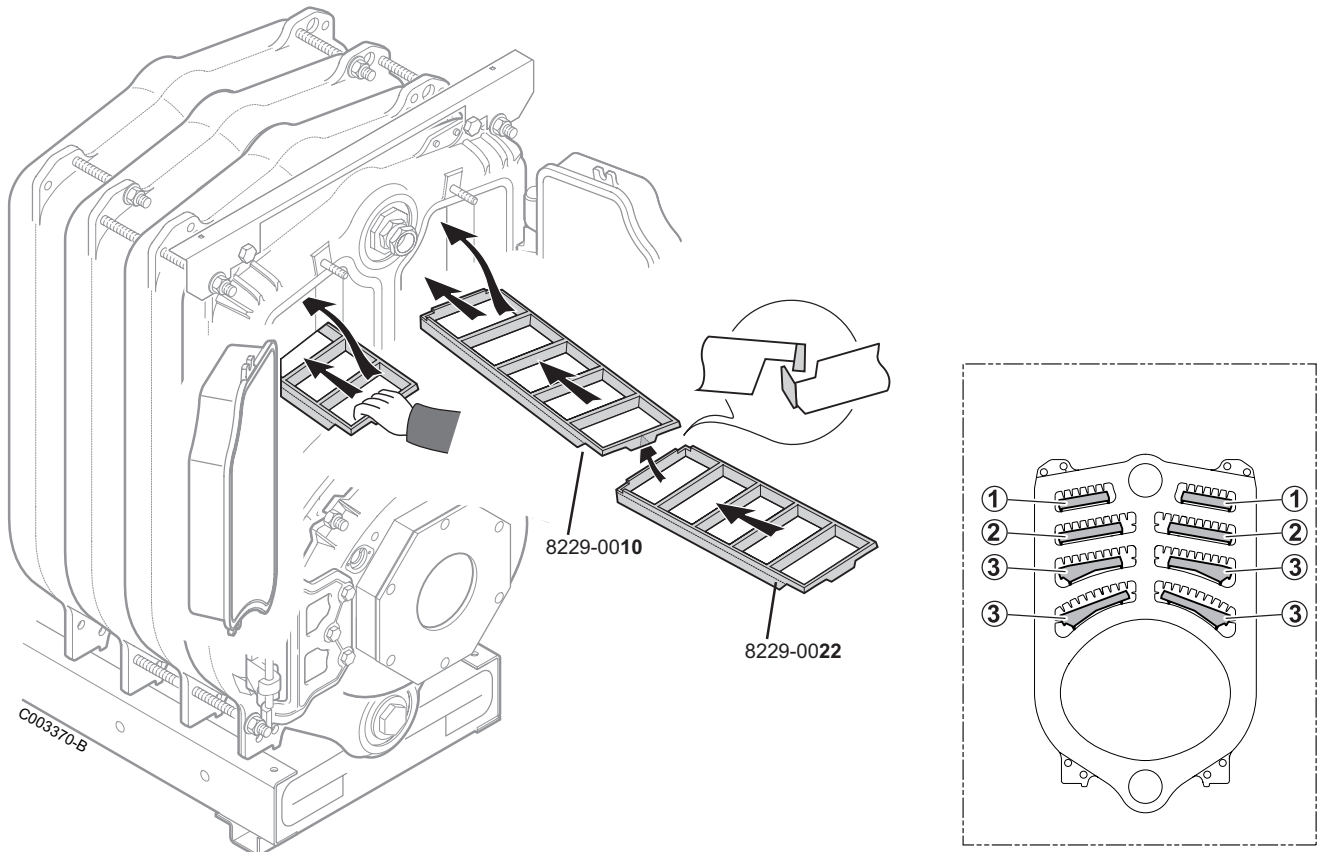

⚠ Follow the order of assembly shown in the diagram.
The 8-figure part number of the baffle plate is cast in the metal.

Boiler		P 420-8	P 420-9 - P 420-10	P 420-11	P 420-12	P 420-13 - P 420-14
Upper flue ways	①	First 8229-0010 then 8229-0022	2 x 8229-0010	First 2 x 8229-0010 then 1 x 8229-0022	First 2 x 8229-0010 then 1 x 8229-0022	3 x 8229-0010
Central flue ways	②	First 8229-0011 then 8229-0023	2 x 8229-0011	First 2 x 8229-0011 then 1 x 8229-0023	First 2 x 8229-0011 then 1 x 8229-0023	3 x 8229-0011
Lower flue ways	③	First 8229-0012 then 8229-0024	2 x 8229-0012	First 2 x 8229-0012 then 1 x 8229-0024	2 x 8229-0012	2 x 8229-0012

7.3.4 Cleaning the flue gas box

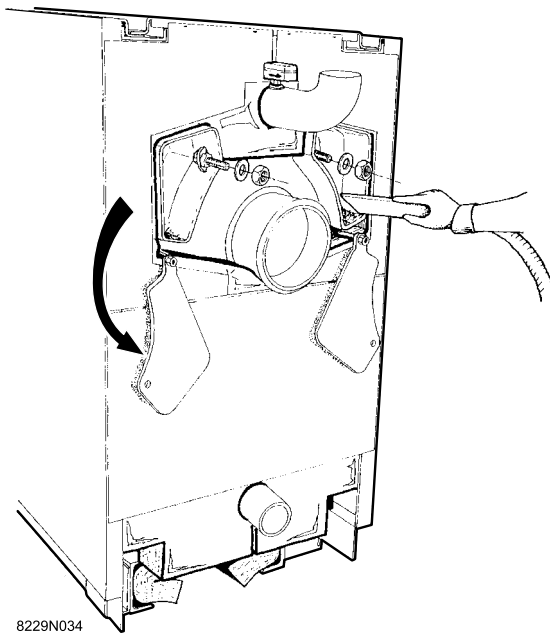

To do so:

- Open the left and right cleaning hatches on the flue gas box (2 nuts H 12 + flat washers with a 19 mm spanner) and remove any soot which has accumulated using a vacuum cleaner.
- Replace the cleaning hatches.

7.3.5 Chemical sweeping

■ General principle

Boilers are traditionally swept mechanically. There are now chemical sweeping methods which facilitate this maintenance work.

A chemical reagent is applied to the boiler's heating surfaces.

After application, the reaction is completed by igniting the burner. The initial deposits are neutralised and pyrolysed. The remaining pulverent residues are easy to remove by sweeping or vacuum cleaning.

■ The products

The product must be suitable for boilers with a cast iron body. Various manufacturers offer products in the form of a concentrated liquid or aerosol.

The aerosols are packaged in 0.5 to 1 l spray cans for treating domestic boilers. Refer to the instructions supplied with the product.

The liquid products are available in 1 to 50 l containers. These concentrated liquids are diluted before application with a spray.

Sprays exist in various forms suitable for their intended use:

- Low capacity (2 or 3 l) spray with built-in reservoir for small boilers and moderate frequency. Manual pressurisation of the reservoir.
- 5 l spray with separate reservoir, nozzle and connecting tube. The nozzles enable easy application at the back of the combustion chamber. Manual pressurisation of the reservoir.
- Motor-assisted pressurisation spray with reservoir, nozzle and connecting tube. These sprays are intended for intensive use.

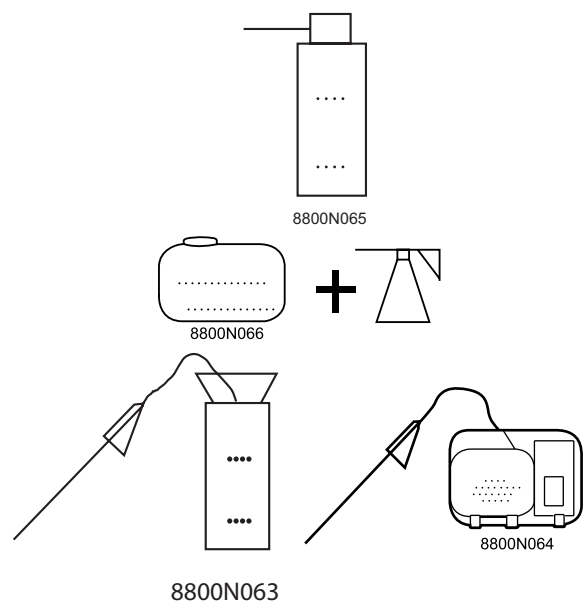

■ Operational mode

The operating mode mentioned corresponds to standard user situations. Refer to the manufacturer's instructions for specific advice on the product used.

■ Application

- Depending on the product, the boiler must be cold or heated. Refer to the instructions supplied with the product.
- Direct application to the heating surfaces with aerosol sprays.
- The concentrates are diluted in the proportions 1/5 to 1/20 (depending on the product and the condition of the boiler).
- Application with the spray is done in the upper part of the boiler and on the walls of the combustion chamber. Surfaces are dampened but not washed. It is not necessary to use the spray to get between the heating surfaces.
- A volume of one litre of solution is generally used for 1 m² of heating surface (domestic boiler), i.e. 0.05 to 0.2 l of concentrate.

■ Ignition

The burner is ignited after allowing the product time to penetrate for 2 to 5 min. Refer to the instructions supplied with the product.

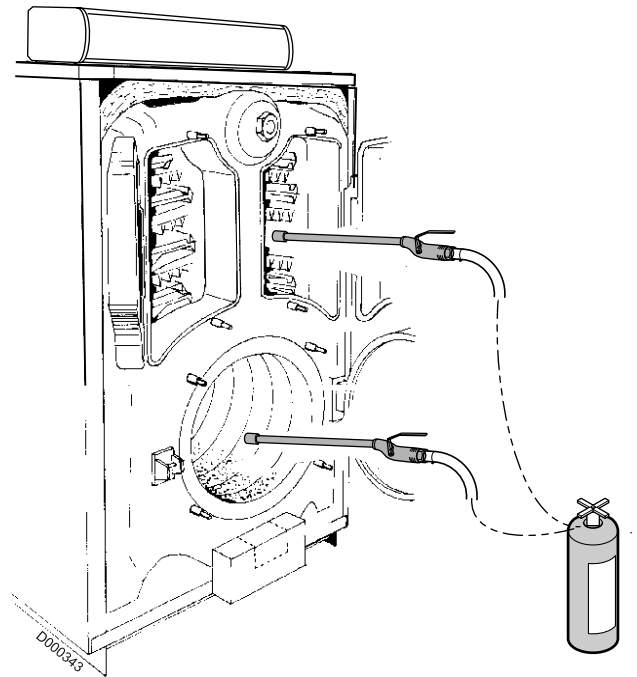

■ Cleaning

- Remove the baffle plates.
- Light sweeping will remove the pulverent residues remaining after combustion.
The remaining pulverent residues are easy to remove by sweeping or vacuum cleaning.
For certain products, brief application after cleaning has a preventive effect, limiting deposits on the heating surfaces.
- Replace the baffle plates.
- Close the door of the combustion chamber.
- Service the burner.
- Replace the front panel.

7.4 Cleaning the casing material

Use a soapy solution and a sponge only. Rinse with clean water and dry with chamois leather or a soft cloth.

7.5 Maintenance of the burner

 Refer to the instructions supplied with the burner.

8 Spare parts

i To order a spare part, quote the reference number next to the part required.

Boiler body

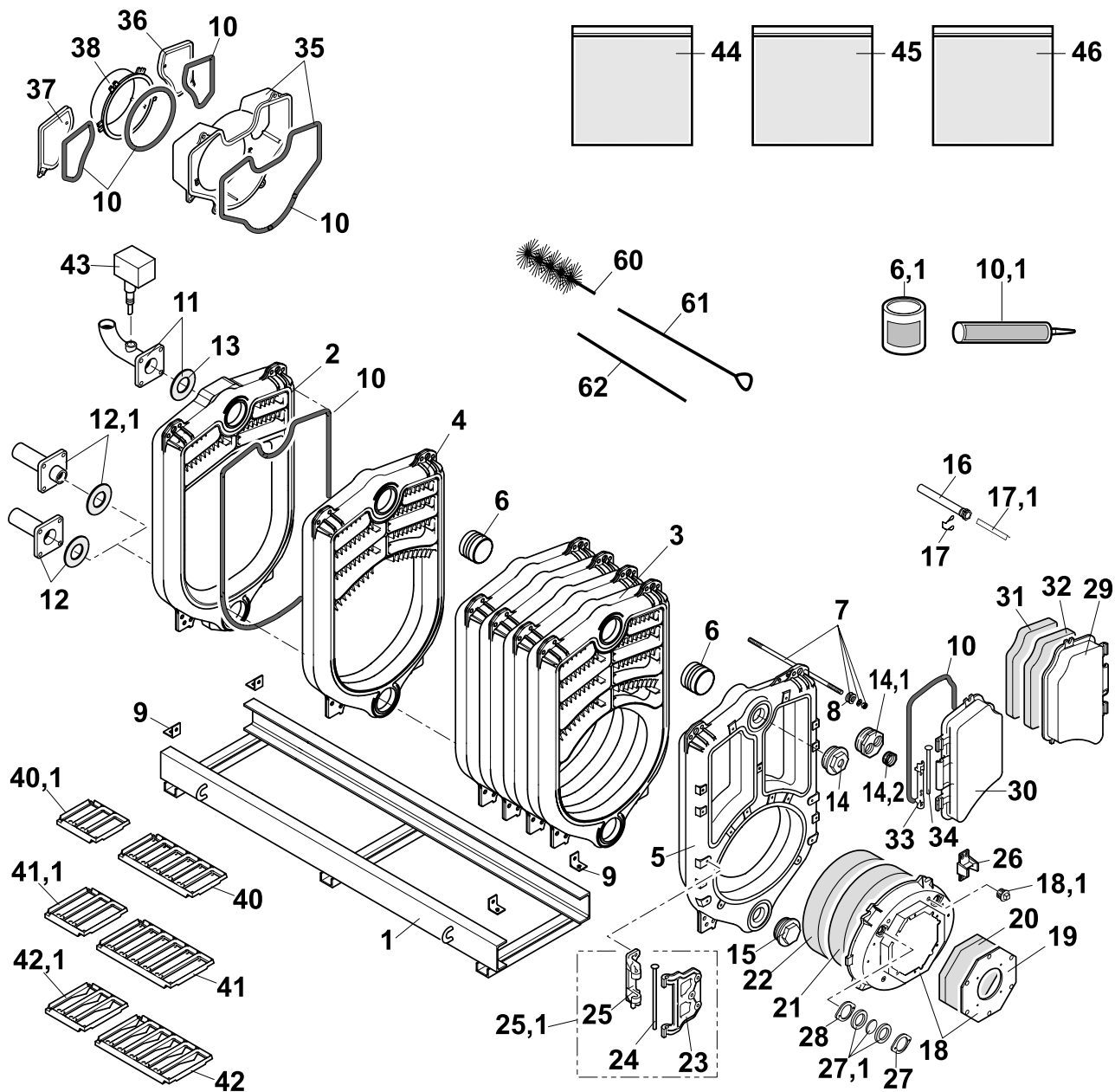

8229N021D

Casing

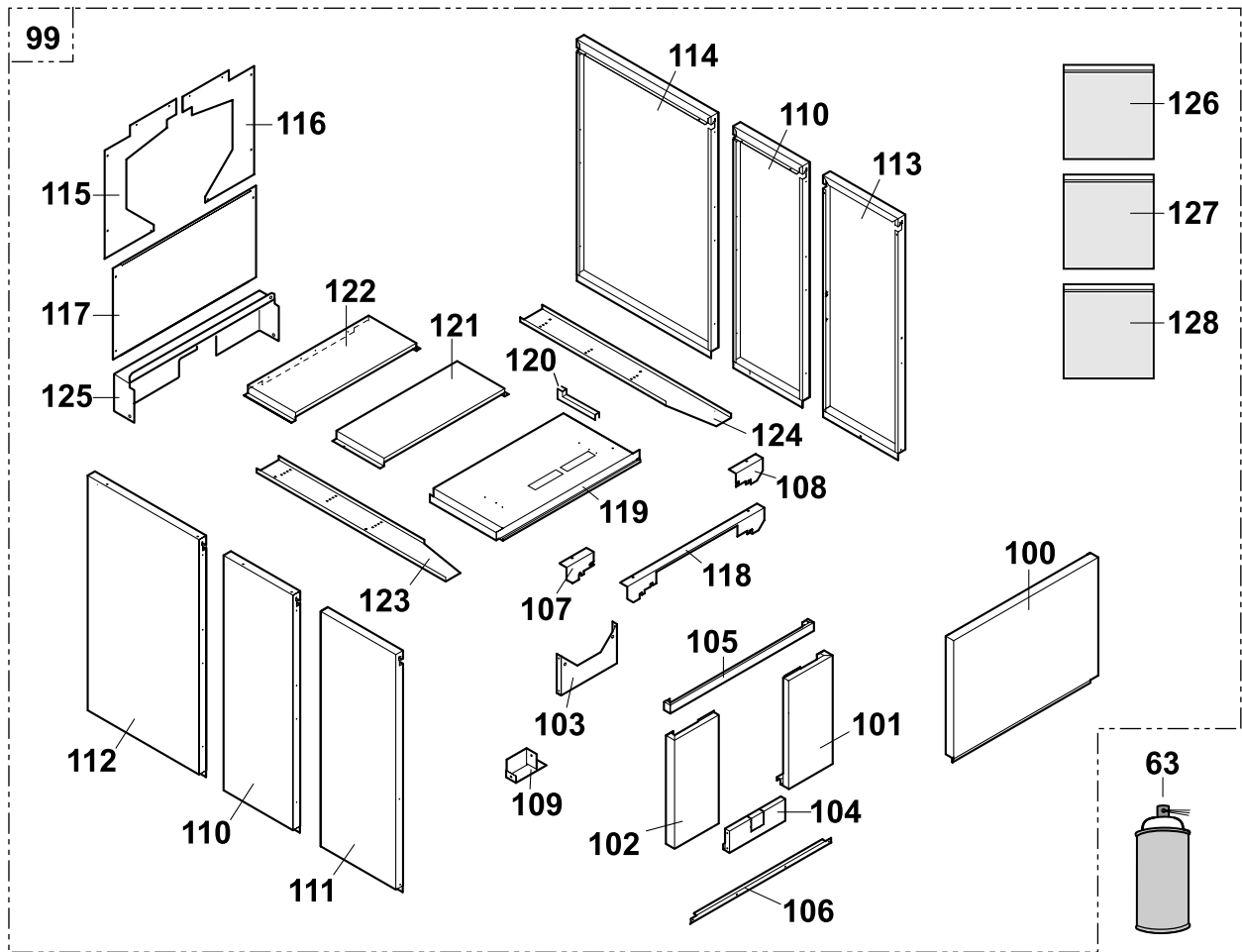

Insulating material for body

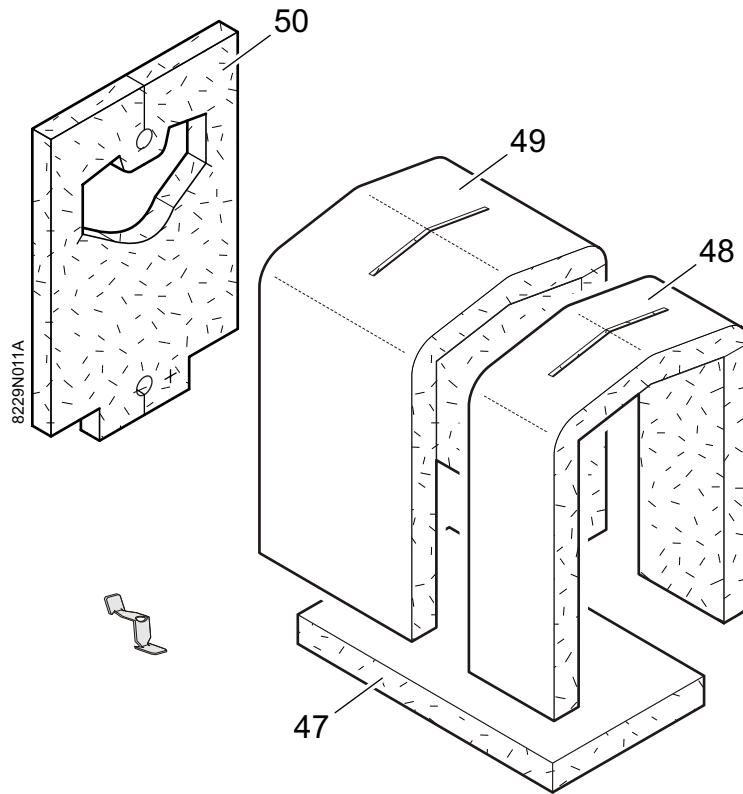

RC 6 control panel

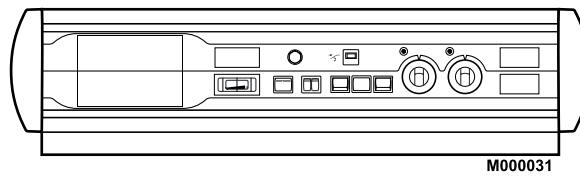

Markers	Code no.	Description
		Boiler body + Accessories
1	300010442	Complete frame 7-8 sections
1	300010443	Complete frame 9-10 sections
1	300010444	Complete frame 11-12 sections
1	300010445	Complete frame 13-14 sections
2	8229-8940	Complete rear section
3	8229-0029	Normal intermediate section
4	8229-0030	Special intermediate section
5	8229-8941	Complete front section
6	8005-0200	Nipple
6.1	9430-5027	Nipple greasing product
7	8229-8919	Assembly rod 425 mm
7	8229-8920	Assembly rod 620 mm
7	8229-8921	Assembly rod 784 mm
8	9754-0120	Spring
9	9752-5232	Mounting square
10	9508-6032	Glass fibre cord \varnothing 10 mm (metre)
10.1	9428-5095	Tube of silicon mastic
11	8229-8923	Water flow pipe + gasket, 7 to 10 sections
11	8229-8918	Water flow pipe + gasket, 11 to 14 sections
12	8104-8965	Return collector + seal, 7 to 10 sections
12.1	8229-8922	Return collector + seal, 11 to 14 sections
13	9501-4135	Gasket 12x120x4
14	8202-0028	2" 1/2 plug with 1/2" opening
14.1	8202-0049	Plug 2 1/2"-1/2"-USA+NL
14.2	9494-8080	Nipple N241-1/2"x1/4"
15	8013-0028	Solid plug 2" 1/2
16	8500-0027	Sensor tube
17	9758-1286	Spring for sensor tube
17.1	9536-5613	Contact spring for sensor tube
18	8229-8911	Complete combustion chamber door, no opening
18	8229-8943	Complete 10 mm combustion chamber door with opening on request
18	8229-8947	Complete 15 mm combustion chamber door with opening on request
18.1	9495-0050	Plug 1/4"
19	8229-0532	Plate for combustion chamber door, no opening
19	8229-0546	Plate for combustion chamber door with opening \varnothing 135
19	8339-0508	Plate for combustion chamber door with opening \varnothing 175
19	8229-0531	Plate for combustion chamber door with opening \varnothing 190
19	8229-0533	Plate for combustion chamber door with opening \varnothing 240
19	8339-0509	Plate for combustion chamber door with opening \varnothing 250
19	8229-0534	Plate for combustion chamber door with opening \varnothing 290

Markers	Code no.	Description
19	8229-0548	Plate for combustion chamber door with opening on request
20	9755-0258	Height converter, insulation
21	9755-0259	Furnace door guard
22	9755-0260	Furnace door insulation
23	8229-0020	Hinge
24	9756-0213	Hinge pin for combustion chamber door
25	8229-0205	Hinge for combustion chamber door
25.1	8229-8944	Hinge unit
26	8229-0025	Ramp
27	9757-0027	Inspection flange
27.1	8015-7700	Flame inspection window + gaskets
28	9501-0080	Flame inspection window gasket
29	8229-8905	Complete sweeping door, right
30	8229-8906	Complete sweeping door, left
31	9755-0256	Insulation, sweeping door
32	9755-0257	Inner protection, sweeping door
33	8229-0202	Hinge for sweeping door
34	9756-0214	Hinge pin for sweeping door
35	8229-8907	Complete flue gas box
36	8229-8908	Complete right-hand cleaning trap
37	8229-8909	Complete left-hand cleaning trap
38	8229-8916	Flue gas nozzle \varnothing 250 - 7 to 10 sections
38	8229-8917	Flue gas nozzle \varnothing 250 - 11 to 14 sections
40	8229-0010	Upper baffle plate, width 190 mm
40.1	8229-0022	Additional upper baffle plate, width 190 mm
41	8229-0011	Upper baffle plate, width 240 mm
41.1	8229-0023	Additional upper baffle plate, width 240 mm
42	8229-0012	Lower baffle plate
42.1	8229-0024	Additional upper baffle plate
		Flow switch
43	8802-4703	Flow controller P 420-7
43	8802-4707	Flow controller P 420-8
43	8802-4710	Flow controller P 420-9
43	8802-4712	Flow controller P 420-10
43	8802-4722	Flow controller P 420-11
43	8802-4725	Flow controller P 420-12
43	8802-4727	Flow controller P 420-13
43	8802-4729	Flow controller P 420-14
44	8229-8936	Screws and accessories bag
45	8229-8937	Variable screws and accessories bag
46	8229-5500	Body screws packet
		Insulating material for body
47	8229-4010	Lower insulation, boiler body - 7 and 8 sections
47	8229-4016	Lower insulation, boiler body - 9 and 10 sections

Markers	Code no.	Description
47	8229-4034	Lower insulation, boiler body - 11 and 12 sections
47	8229-4036	Lower insulation, boiler body - 13 and 14 sections
48	8229-4004	Front boiler body insulation, width 500 mm
49	8229-4015	Boiler body insulation, width 500 mm
49	8229-4018	Boiler body insulation, width 600 mm
49	8229-4009	Boiler body insulation, width 800 mm
49	8229-4012	Boiler body insulation, width 900 mm
50	8229-4005	Rear insulation
		Miscellaneous
60	9750-5025	Brush
61	9750-5060	1300 mm brush rod
62	9750-5048	Extension for brush rod 650 mm
63	9434-5102	Retouching spray paint - anthracite grey
63	9434-5104	Retouching spray paint - ivory
		Casing
100	200003654	Complete upper front panel
101	8229-1001	Complete lower front panel, right
102	8229-1003	Panel for furnace door
103	8229-1004	Complete lower front panel, left
104	8229-1005	Sludge removal cap
105	8229-8834	Complete front casing support
106	8229-0537	Lower front crosspiece
107	8229-8807	Upper casing support, left
108	8229-8808	Upper casing support, right
109	8229-8010	Lower casing support
		Front side casing - before week 14 / 2008
110	8545-0500	Side panel, left or right, width 480 mm
111	8545-8006	Complete front side panel, left
112	8545-8004	Complete side panel, left, width 770 mm
112	8545-8003	Complete side panel, left, width 610 mm
112	8545-8005	Complete side panel, left, width 930 mm
113	8545-8007	Complete front side panel, right
114	8545-8000	Complete side panel, right, width 610 mm
114	8545-8001	Complete side panel, right, width 770 mm
114	8545-8002	Complete side panel, right, width 930 mm
		Front side casing - after week 14 / 2008
110	200007889	Side panel, left or right, width 480 mm - Grey
111	200007422	Complete front side panel, left - Grey
112	200007896	Complete side panel, left, width 770 mm - Grey
112	200007894	Complete side panel, left, width 610 mm - Grey
112	200007898	Complete side panel, left, width 930 mm - Grey
113	200007421	Complete front side panel, right - Grey
114	200007893	Complete side panel, right, width 610 mm - Grey
114	200007895	Complete side panel, right, width 770 mm - Grey
114	200007897	Complete side panel, right, width 930 mm - Grey

Markers	Code no.	Description
115	8229-8835	Complete upper rear panel, left
116	8229-8836	Complete upper rear panel, right
117	8229-8012	Lower back panel
118	8229-8837	Complete upper cross-bar
119	8229-8809	Complete front cover
120	9755-0187	Rubber profile for cable way
121	8229-0515	Complete intermediate cover
122	8229-0518	Complete rear cover, width 170 mm
122	8229-0511	Complete rear cover, width 330 mm
122	8229-0514	Complete rear cover, width 490 mm
123	8229-8818	Complete cable way, left, P 420-7
123	8229-8819	Complete cable way, left, P 420-8
123	8229-8820	Complete cable way, left, P 420-9
123	8229-8821	Complete cable way, left, P 420-10
123	8229-8822	Complete cable way, left, P 420-11
123	8229-8823	Complete cable way, left, P 420-12
123	8229-8824	Complete cable way, left, P 420-13
123	8229-8825	Complete cable way, left, P 420-14
124	8229-8826	Complete cable way, right, P 420-7
124	8229-8827	Complete cable way, right, P 420-8
124	8229-8828	Complete cable way, right, P 420-9
124	8229-8829	Complete cable way, right, P 420-10
124	8229-8830	Complete cable way, right, P 420-11
124	8229-8831	Complete cable way, right, P 420-12
124	8229-8832	Complete cable way, right, P 420-13
124	8229-8833	Complete cable way, right, P 420-14
125	8229-5501	Additional lower rear panel
126	8229-8933	Screw bag, common parts
127	8229-8934	Screw bag, variable parts CS11
128	8229-8935	Screw bag, variable parts CS13
		K - RC 6 control panel
		Refer to the connection instructions supplied with the control panel..

- NL Remeha B.V.**
Postbus 32
7300 AA APELDOORN
Tel: +31 55 5496969
Fax: +31 55 5496496
Internet: nl.remeha.com
E-mail: remeha@remeha.com
- B J.L. Mampaey BVBA**
Uitbreidingstraat 54
2600 ANTWERPEN
Tel: +32 3 2307106
Fax: +32 3 2301153
Internet: www.mampaey.be
E-mail: info@mampaey.be
- B Thema S.A.**
6, Avenue de l'expansion
4460 GRACE-HOLLOGNE
Tel: +32 4 2469575
Fax: +32 4 2469576
Internet: www.thema-sa.be
E-mail: info@thema-sa.be
- E Termibarna S.A.**
C. Zamora 55-59
08005 BARCELONA
Tel: +34 3 3000204
Fax: +34 3 3009558
- E D.A.C. S.A.**
Tomás A. Edison 29
Poligono Cogullada
50014 ZARAGOZA
Tel: +34 76 464076
Fax: +34 76 471311
Internet: www.dac.es
E-mail: dac@dac.es
- E Cuatrocesa S.A.**
c) Sor Angela de La Cruz, 10
- 1º Oficina C
28020 MADRID
Tel: +34 91 658 18 88
Fax: +34 91 658 30 77
- E Norte Comercial Organización S.A.**
Bereteage Bidea, 19
48180 LOIU (Vizcaya)
Tel: +34 94 471 03 33
Fax: +34 94 471 11 52
E-mail: nco@nco.es
- GB Remeha Commercial UK**
Part of the BDR THERMEA
Remeha House
Molly Millars Lane
RQ41 2QP Wokingham, Berks
After Sales Tel: 01189743076
Technical Enquires: 01189743067
Internet: www.remeha.co.uk
- H Marketbau - Remeha Kft.**
Gyár u. 2.
Ipari Park
2040 BUDAÖRS
Tel: +36 23 503 980
Fax: +36 23 503 981
Internet: www.remeha.hu
E-mail: remeha@remeha.hu
- IRL Euro Gas Ltd.**
Unit 38, Southern Cross Business Park
Boghall Road, Bray, Co
WICKLOW
Tel: +353 12868244
Fax: +353 12861729
Internet: www.eurogas.ie
E-mail: sales@eurogas.ie
- IT Revis S.r.l**
Via Trieste 4a
31025 Santa Lucia di Piave (TV)
Tel: +39 0438 701907
Fax: +39 02 36028583
Internet: www.re-vis.it
E-mail: info@re-vis.it

© Copyright

All technical and technological information contained in these technical instructions, as well as any drawings and technical descriptions supplied, remain our property and shall not be multiplied without our prior consent in writing.

Subject to alterations.

16/03/2016



300016839-001-03